

The Hammerman Equipment



Plastic Piling Mandrels







Piling Mandrels

Steel fabrications used to assist and speed up the installation of plastic sheet piling.



- ⇒ Increases the rigidity of the plastic sheet pile
- ⇒ Helps drive sheets in to hard soil and passed obstructions
- ⇒ Reduces toe resistance during installation
- ⇒ Helps supports the use of larger piling vibrators

Handheld Pile & Post Drivers
Plastic Piling Mandrels
EMS Series Mini Piling Vibrators

	@plasticpiling		Plastic Piling
	@plasticpiling		@PlasticpilingNinja
	@plasticpiling		PlasticPiling
	THEPlasticPiling	Follow us on	
	@plasticpiling		



Plastic Piling installation

Plastic sheet piling provides many advantages over traditional piling; be this timber piles or steel sheet piling. These advantages include huge cost savings due to the longevity and maintenance free aspects of a material that does not rust or rot. Improved health and safety through easier and safer handling, due to the lower weight. A more environmental solution, the use of recycled material combined with the low weight means that transportation is more efficient; so less loads to site reducing the overall environmental disturbance. Improved performance in water control, better designed pile interlock creates a far more effective water barrier than trench sheeting. However, PVC is a more flexible material than steel and this introduces a host of installation challenges.

One of the main issues limiting the successful installation is the scarcity of equipment suitable for plastic piling and in many respects trench sheeting. Compared to steel piling there is simply not the myriad of equipment available to provide a solution to all ground conditions. The introduction of excavator mounted vibrators, has brought substantial gains in this areas, but has done little to address the imbalance created due to the limited availability of impact hammers. In steel piling, upon refusal, it is an established practice to back drive with quite large impact hammers.

In terms of plastic piling, with the exception of small air hammers and adapted hydraulic breakers, there is not a viable back driving method. The recent development of the BSP BH120 hydraulic impact hammer, will help to address this, but only once its made more available. Until then plastic piling has to rely solely on vibratory hammers, and as such installation of plastic sheet piling is limited by the effectiveness of such equipment. This in turn creates a reliance on the ability to work with much larger, more powerful units to compensate for non-ideal soil conditions. It is commonly stated that piling vibrators work best in granular soils, where the vibrations clearly have the greatest affect and they do not drive into clay soils. Nothing is ever that clear cut, if the ground is purely granular a piling vibrator is as likely to compact the soil, as to drive through it. Likewise in a clay soil, if mixed with sand, silt, gravel then the vibrator will drive through just as easy. In clay and cohesive soils, vibrators are less effective, as the soil does not fluidize easy. However, with the advent of excavator mounting much will depend upon the thickness of the layers of soil, and in many cases the vibrators will typically be able to drive through bands of up to 1 metre of non ideal soil.

A general rule of thumb, that provides a limit for vibrators is an SPT (Standard Penetration Testing - blows per metre) levels over 30N. Between 30N-50N SPT brute force (and so more powerful equipment) does improve the driveability; but only if the pile can withstand such high forces. Further, many sites particularly those interested in plastic piling, have a restricted access and as such there are limits placed upon the size of the equipment that can be used in any event.

Plastic Piling mandrels facilitate the use of larger vibratory equipment as these strengthen the piles, help support the vibrator and piles during installation, whilst in some case help guide away obstructions. Mandrels are available in a range of designs including sleeves, rear and side mandrels and of course internal mandrels as developed for our Advanced range of plastic sheet piling.

Plastic sheet piling, particularly the thin narrow designs proved more flexible and prone to twisting. The secret to installing plastic piling is maximising and increasing the rigidity, and so making the process as efficient as possible - mandrels help achieve this.



Side Sleeves

The inability of light duty plastic sheet piling to support the weight of a piling vibrator, seriously limited the ability of these products to be installed efficiently. To facilitate this driving aids were introduced, the first is the side sleeve. This is the lightest of all the driving aids produced, and this enables its use with small piling vibrators, that have low amplitudes - such as the EMV70 shown.

The side sleeve, based upon an idea from an Environment Agency site, is a basic light weight steel fabrication, designed to slide over the plastic pile male interlock—NOT whole pile, and provides additional strength and rigidity. The piling vibrator now grips and is now supported by the side sleeve and the vibration generated imparted through the sleeve into the pile and surrounding soil. In addition to greater productivity, this method also served to reduce top damage to the plastic pile, something common when working with small air hammers.

The limitation in this concept is the length that can realistically be handled, side sleeves up to 3 metres are feasible, above this handling becomes an issue as the sleeve needs to be slid over the plastic pile.

To ensure that the sleeve does not become plugged, it must always be shorter than the plastic pile driven.

When using a Side Sleeve it is advisable to build a base frame, as the centre of gravity will have been moved to the interlock and the Side Sleeve will tend to rotate, so means are needed to resist this.

With the introduction of strong, more rigid plastic piles, side sleeves are now exclusively used on light gauge plastic piling, such as the standard EcoZ and trench pile profiles.

Plus the introduction of our own EMS Series vibrators, including our own ESF03 Mini 'vibro' hammer has reduced the dependency that plastic piling had on small air hammers. These air hammers have long been the industry workhorse, but are extremely noisy, operate a polluting open lubrications system. And in hard driving can cause substantial top damage to the sheet.



Rear Mandrels

Rear mandrels, exemplified by such designs as the Stabcat Stomper and the CMI PileClaw, proved that it was possible to drive extremely long lengths of plastic piling. These mandrels consisted of a steel replica of the plastic pile, typically with some form of toe grip, the mandrel positioned immediately behind the pile.

The method is flawed for the following reasons:

- The method provided for these mandrels, includes a section on re-driving the pile once it has been pulled out of the ground, during mandrel extraction. This is not surprising as once driven there is as much contact between the mandrel and plastic pile, as there is between the plastic pile and the soil.
- With rear, top and bottom retention, the one axis that is unsupported is the sides, and it is common in pictures to see vice clamps holding the pile, to prevent the pile from buckling during installation. This introduced the necessity of re-adjusting the grips during the installation, and so involves operators entering into a dangerous location beneath the pile driver.

It is for these reasons why we do not supply this type of mandrel. Our version of this concept are the side mandrels shown overleaf. Recent advances in rear mandrels have introduced element of passive side support, and in the latest PileClaw patents an active side grip has been proposed. This side support does make the designs much safer, however the issue of pile pull out has not been addressed sufficiently.

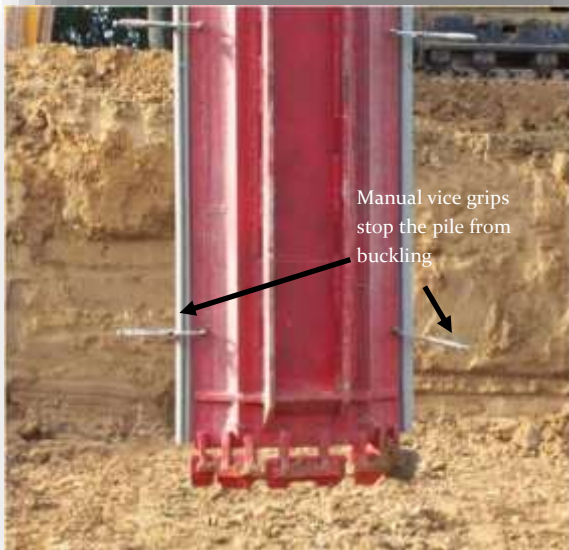

Passive side grip

Newly proposed active grip

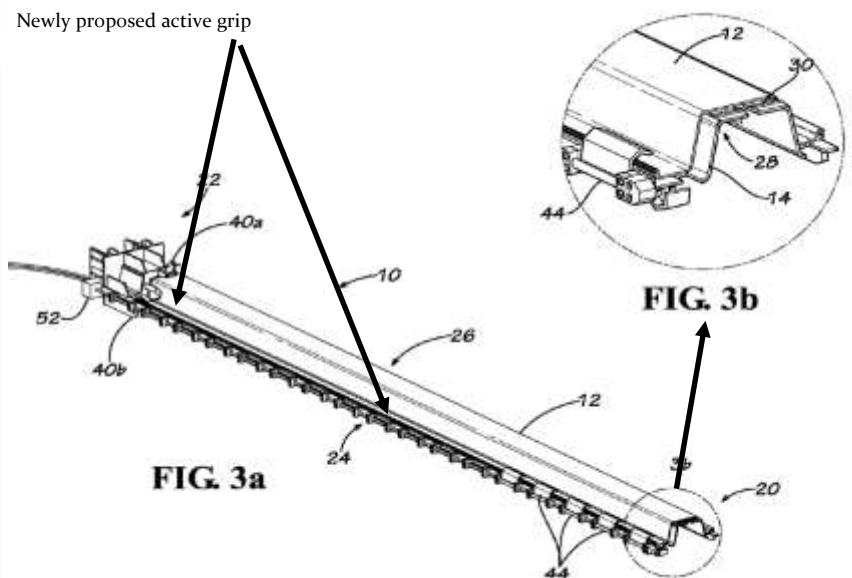



Side Mandrels

As the name suggests, this mandrel is positioned to the side of the plastic pile, rather than behind it. The concept is to increase rigidity of the plastic piling, support the weight of the piling vibrator, whilst minimising the surface contact between the mandrel and pile. In summary, more support with minimal contact - the pile is driven efficient and stays in the ground.

Side support is essential, else the pile will drift, buckle or flex away from the mandrel. This in turn will reduce driving efficiency, and increase the chance of de-clutching or damaging the sheet pile. The recent addition of passive and now active side gripping in rear mandrels simply confirms this.

The side mandrel is first driven on its own, this clears away major obstructions, and in some soil conditions it will leave behind a pile shaped hole. The plastic pile is then inserted into the mandrel, and the combined assembly driven into the ground. The pile is driven more efficiently as there is reduced toe resistance, whilst benefiting from top and side support.

The mandrel is then extracted, and since there is minimal contact between it and the pile, the pile stays in the ground. So unlike rear mandrels there is no need for a re-drive method.

There are limitations based upon the type of vibrator, excavator mounted vibrators will typically drive shorter lengths, even with a swan neck, compared to a leader mounted vibrator. The verticality of the drive and the control over this becomes more important the longer the mandrel.

In the UK the longest we have worked with is 5-6 metres, in other countries lengths of up to 14 metres have been driven.





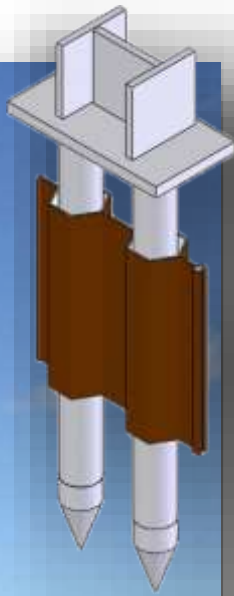

Internal Mandrels

Internal mandrels, are basic steel fabrications that are inserted into the inside area of a plastic pile - only available with advanced plastic piles. The mandrels are much lighter; this in turn enables smaller piling vibrators to be used, or for a given size of vibrator makes that pile driver more efficient.



Recycled PVC will never provide the same strength and rigidity of steel, when used in similar designs and dimensions. Traditional plastic sheet piling made attempts to compensate for this through exaggerating the design of the sheet piling. Rather than optimise design, material was added creating thicker, deep and ribbed products such as the Ultra U and Ultra Z plastic piles. This provided better rigidity and in turn enabled more efficient installation, primarily through the use of larger piling equipment.

The introduction of the advanced range of plastic piling, by THE Plastic Piling Company, has revolutionised the installation of plastic piling. These tubular designs, have taken the design of sheet piling beyond that possible with steel piling. These designs offer better rigidity and are less inclined to buckle. However in terms of this publication, Piling Mandrels, their introduction enabled a substantial improvement in mandrel design.

Whilst side mandrels do offer substantial performance and safety advantages over rear mandrels, they are very heavy and this in turn influences what piling vibrators can be used. All piling vibrators are designed with a maximum pile mass in mind, above this performance and mechanical stability of the vibrator becomes affected. The heavier the pile, the higher the amplitude of the piling vibrator needs to be, as the

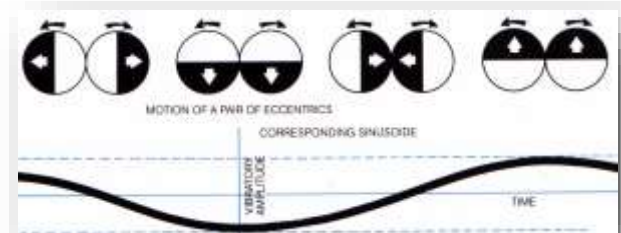

Amplitude is best described as the measure of vertical movement of a given vibrator, the higher the amplitude the more aggressive the piling vibrator appears. Therefore when using side or rear mandrels, these are in essence very heavy piles and so require vibrators with high amplitudes. The consequence of this is the scale as everything get bigger, and larger equipment means greater environmental disturbance. In terms of vibratory equipment side mandrels ideally require a piling vibrator which operates with at least 8 mm of amplitude.



In contrast, internal mandrels extend the use of mandrels to much smaller vibrators, with amplitudes as low as 3mm. This enables the use of mandrels in access restricted sites.

The internal mandrels provide additional rigidity to the pile during installation. The process of installation is made more efficient as the mandrel extends beyond the pile and guide soil and obstructions out of the way, reducing toe resistance.

The internal mandrel is extremely well balanced as it is located inside the plastic pile, and place it and the pile directly beneath the vibrator where it is most effective. Upon extraction of the mandrel, the pile always remains in place as the skin friction on the outside of the pile is always more than that on the inside.

So minimal contact, maximum support.





T  **E**
Tel 01543 677290
Plastic Piling Company
www.plasticpiling.ninja



Other products available

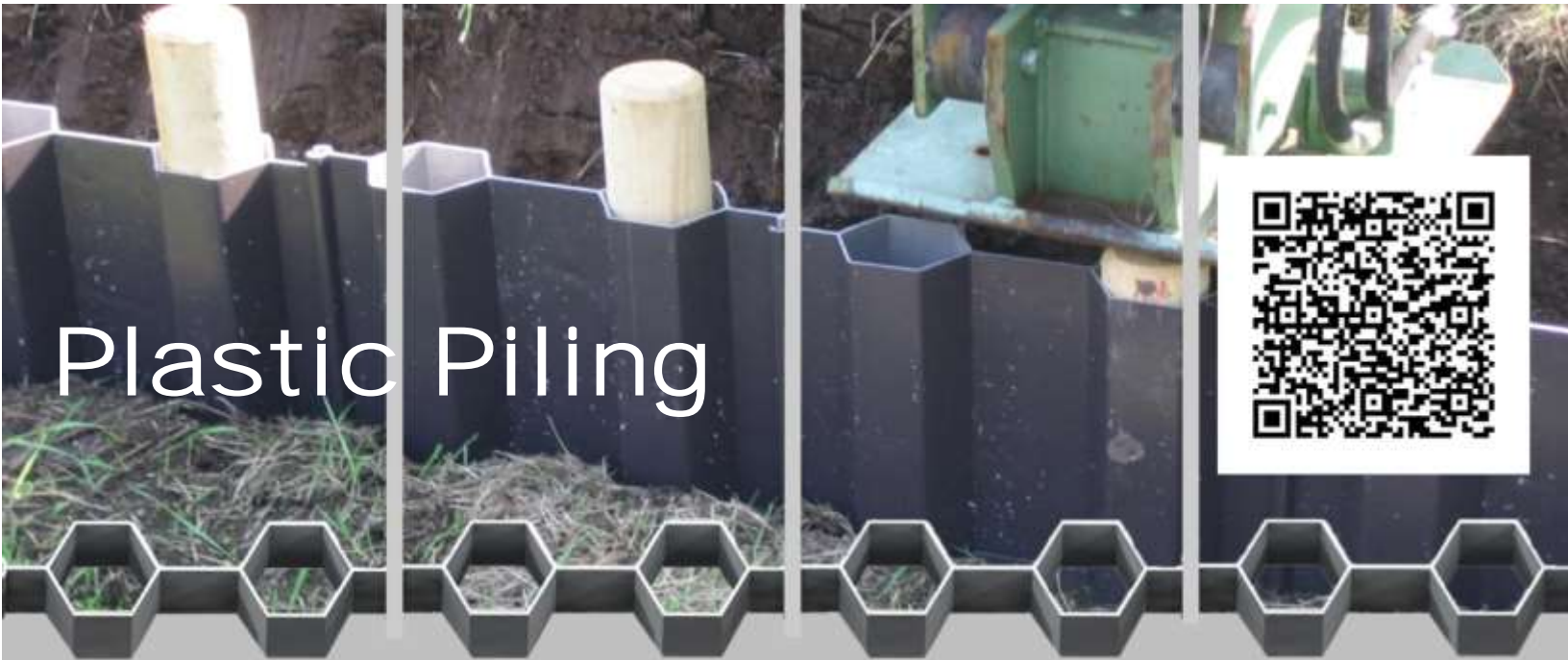

Plastic Piling



Piling Vibrators





Aldridge Piling Equipment
01543 277680
www.miniape.com
www.miniape.co.uk



IMPORTANT NOTE

Mandrels are steel fabrications that are available for hire and sale. When hired please note, the onus is on the hirer to maintain the mandrels in working order. If it is not viable to hire mandrels, offering a free breakdown service covering the whole of the UK, whilst maintaining realistic and accessible hire rates.

Mandrels will be supplied in a good condition, but repeated driving can result in breakages. This is normal and to be expected.

This is why we always recommend that mandrels are hired in pairs to avoid downtime, whilst you conduct any necessary repairs.

If you are unable to maintain the mandrels whilst on hire, we will happily arrange at cost to collect, repair and return.

The Hammerman Equipment

Unit 19 Cinder Road
Zone 3 Burntwood Business Park
Burntwood
Staffs
WS7 3FS