

Ultra U61 & PU600
Plastic Pile
Specifications

		U610/6.4	U610/702	U610/9	PU600
Ultimate Moment	kNm/m	23.1	31.2	44.1	38.7
Allowable Moment (FOS=3) (M)	kNm/m	7.7	10.4	14.7	12.9
Section Modulus (Z)	cm ³ /m	580	780	1100	967
Moment of Inertia (I)	cm ⁴ /m	5174	7895	12576	10633
Effective Pile Width	mm	610 ± 15	610 ± 15	610 ± 15	600
Depth of Section	mm	180	200	230	220
Thickness	mm	6.4	7.2	9	8
Material		U = mono extruded PU = Co extruded PVC			
Weight per m (product)	Kg	8	9.8	12.5	13.5
Modulus of Elasticity	MPa	2600			

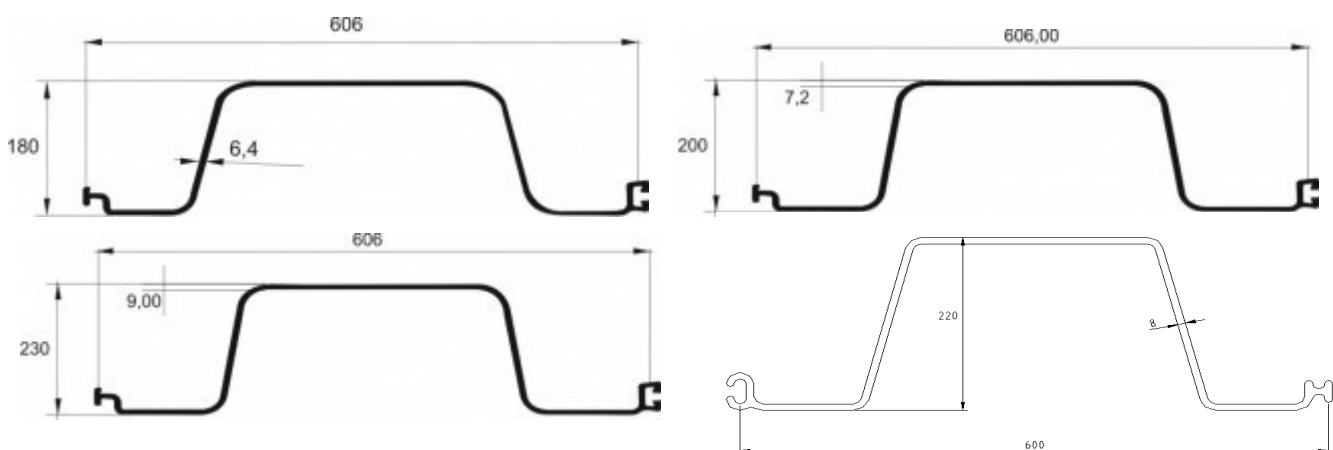

Unit 19 Cinder Road Zone 3 Burntwood Business Park Staffordshire WS7 3FS

Tel: 01543 677290 | Mob: 07775 710648 | Tel: 0845 519519 7

Skype: apeplasticpiling Twitter: @plasticpiling www.plasticpiling.ninja